

# VIBRATION ISOLATOR

NOISE & VIBRATION CONTROL PRODUCT

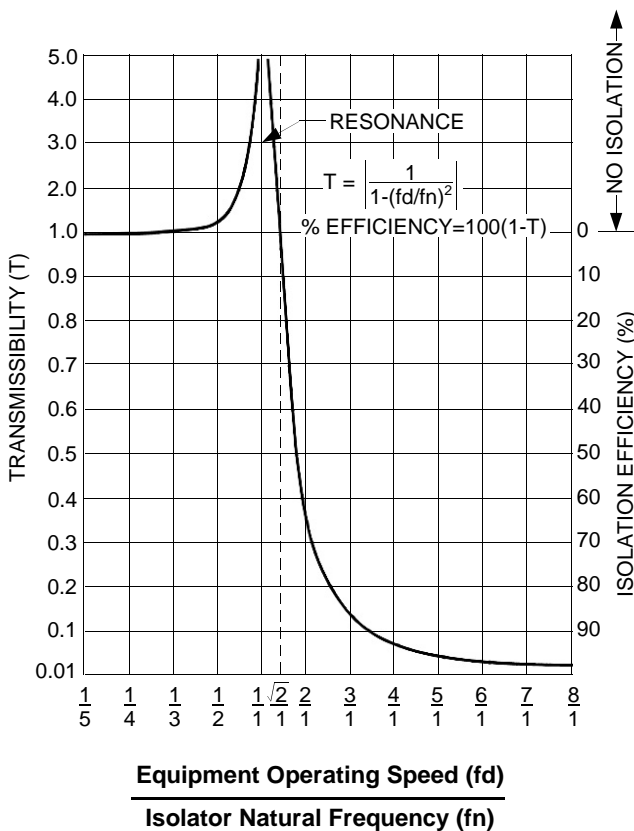


Today, most of sophisticated buildings are provided with air conditioning systems and other equipments to create a comfortable working or living environment. However, these mechanical equipments generate vibration and vibration induced noise, which has become a major sources of occupant complaint in modern buildings. The noise and vibration problem is compounded by increasing uses of lighter weight construction and equipments located in penthouses or intermediate level mechanical rooms. It increased structure borne vibration and noise transmission. Not only is the physical vibration in the structure disturbing, but noise which is regenerated by the structural movement may also be heard in other remote sections of the building structure.

the  $fd = fn$ , the system resonance occurs, the exciting forces will be amplified rather than reduced. As isolator natural frequency,  $fn$ , becomes lower than distributing frequency,  $fd$ , the isolation range is entered when the ratio of  $fd/fn$  becomes bigger than  $\sqrt{2}$ .

In Figure 2, the formula expressed the natural frequency of the isolator is a function of isolator deflection. Theoretically, it is desirable to select isolators with a natural frequency as far below the equipment operating speed as possible to achieve the highest degree of vibration control. However, when the ratio approaches 6:1, it takes very large increases in static deflection to reduce isolator natural frequency and further reduce transmission.

**VIBRATION TRANSMISSIBILITY CURVE FOR AN ISOLATED SYSTEM**



( Fig. 1 )

TOZEN vibration and noise control products are designed to isolate or reduce the damaging structure vibration and annoying noise produced by the mechanical equipments. Owing to continuous research and development program, Tozen vibration and noise control products are recognized as a best solution to every day problems and for complex applications requiring optimum vibration and noise control.

Effectiveness of the vibration control, or vibration isolating efficiency is a function of the ratio of the equipment operating frequency,  $fd$ , to isolator natural frequency,  $fn$ . Figure 1 shown a typical vibration transmissibility curve for vibrating equipments supported on isolators. When

$$fn = 947 \sqrt{\frac{1}{\text{deflection in mm.}}}$$

( Fig. 2 )

Theoretical isolation efficiency shown on the transmissibility curve (Fig. 1) assumes the isolators are located on a rigid floor. This rigidity seldom occurs in above grade applications. In practice, considerable building deflection can occur, which may reduce the effectiveness of the vibration isolators. Vibration isolators must be selected to compensate for the floor deflection. Longer spans also allow the structure to be more flexible, permitting the building to be more easily set in operating speeds, equipment horsepower, damping and other factors have been taken into consideration.

By specifying Tozen vibration isolator by type and deflection rather than isolation efficiency, transmissibility, or other theoretical parameters. The consulting engineer can compensate for floor deflection and building resonances by selecting isolators which are satisfactory to provide minimum vibration transmission and which have more deflection than the supporting floor.

When the specifier permits equipment suppliers to provide "appropriate" isolators, which are not manufactured under Tozen or equivalent high Standards, a satisfactory job is not ensured, since different brands of isolators may be furnished and no one supplier except Tozen can carry the full responsibility for a building free of vibration and noise as specified.

To apply the information from the Selection Guide, base type, isolator type, and minimum deflection, columns are added to the equipment schedule, and the isolator

## Selection Guide for Tozen Vibration Isolator

EQUIPMENT TYPE Category & Capacity	GRADE SUPPORTED SLAB			6 METER FLOOR SPAN			9 METER FLOOR SPAN			12 METER FLOOR SPAN			15 METER FLOOR SPAN		
	Base Type	Isolator Type	Min. Deflection	Base Type	Isolator Type	Min. Deflection	Base Type	Isolator Type	Min. Deflection	Base Type	Isolator Type	Min. Deflection	Base Type	Isolator Type	Min. Deflection
<b>Refrigeration Machines</b> - Reciprocating Chillers - Centrifugal Chillers - Open Centrifugal Chillers - Absorption Chillers	A	2	6	A	4	20	A	4	40	A	4	65	A	4	65
	A	1	6	A	4	20	A	4	40	A	4	65	A	4	65
	C	1	6	C	4	20	C	4	40	C	4	65	C	4	65
	A	1	6	A	4	20	A	4	40	A	4	65	A	4	65
<b>Air compressors</b> - Tank Mounted - Base Mounted	A	3	20	A	3	20	A	3	40	A	3	65	A	3	65
	C	3	20	C	3	20	C	3	40	C	3	40	C	3	65
<b>Pumps-Close coupled</b> - Up to 6 kW - 7.5 kW & over	B/C	2	6	C	3	20	C	3	20	C	3	20	C	3	20
• Flexible coupled - Up to 30 kW - 37 to 93 kW - 110 kW & over	C	3	20	C	3	20	C	3	40	C	3	40	C	3	40
	C	3	20	C	3	20	C	3	40	C	3	40	C	3	65
	C	3	20	C	3	20	C	3	40	C	3	40	C	3	65
	C	3	20	C	3	20	C	3	40	C	3	40	C	3	90
<b>Cooling Towers</b> - Up to 300 rpm - 301 to 500 rpm - 501 rpm & over	A	1, 2	6	A	4	65	A	4	90	A	4	90	A	4	90
	A	1, 2	6	A	4	65	A	4	65	A	4	65	A	4	90
	A	1, 2	6	A	4	20	A	4	40	A	4	40	A	4	65
	A/B	2	6	A/B	3	20	A/B	3	20	A/B	3	20	A/C	3	40
<b>Axial, Tubular &amp; Fan heads</b> - Up to 550mm dia. • 600mm wheel dia. & over	B/C	3	65	C	3	90	C	3	90	C	3	90	C	3	90
	B/C	3	20	C	3	40	C	3	65	C	3	65	C	3	65
	B/C	3	20	C	3	40	C	3	40	C	3	40	C	3	65
	A/B	2	6	A/B	3	20	A/B	3	20	A/B	3	20	A/C	3	20
<b>Centrifugal Fans &amp; Vent Sets</b> - Up to 550mm wheel dia. • 600mm wheel dia. & over - Up to 37 kW	B	3	65	B	3	90	B	3	90	B	3	90	B	3	90
	B	3	40	B	3	40	B	3	40	B	3	65	B	3	65
	B	3	20	B	3	20	B	3	20	B	3	40	B	3	65
	B/C	3	65	C	3	90	C	3	90	C	3	90	C	3	90
<b>Packaged Air Handling Equipments</b> - Up to 7.5 kW • 11 kW & over - Up to 500 rpm - 501 rpm & over	A	2	6	A	3	20	A	3	20	A	3	20	A	3	40
	A	2	6	A	3	20	A	3	40	A	3	40	A	3	65
	A	2	6	A	3	20	A	3	40	A	3	40	A	3	65
	A	2	6	A	3	20	A	3	40	A	3	40	A	3	65

**Base Types :**  
A = No base, isolators attached directly to equipment  
B = Structural steel rails or base  
C = Concrete inertia base

**Isolator Types :**  
1 = Rubber pad  
2 = Rubber floor isolator and hanger  
3 = Unhoused floor isolator or hanger  
4 = Restrained spring isolator

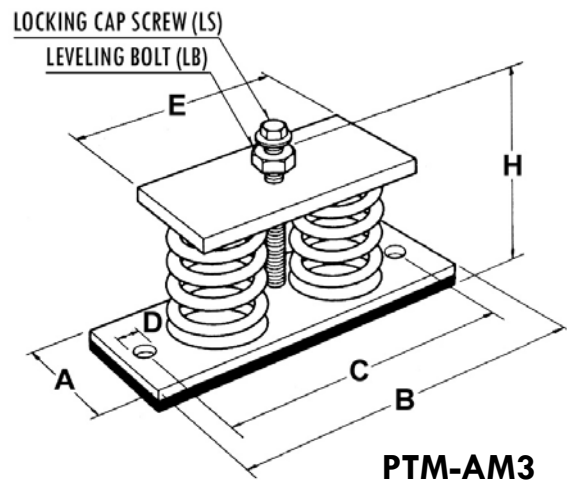
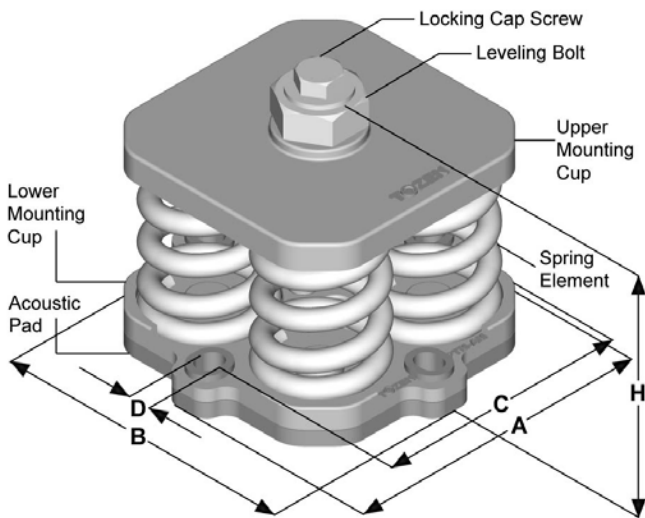
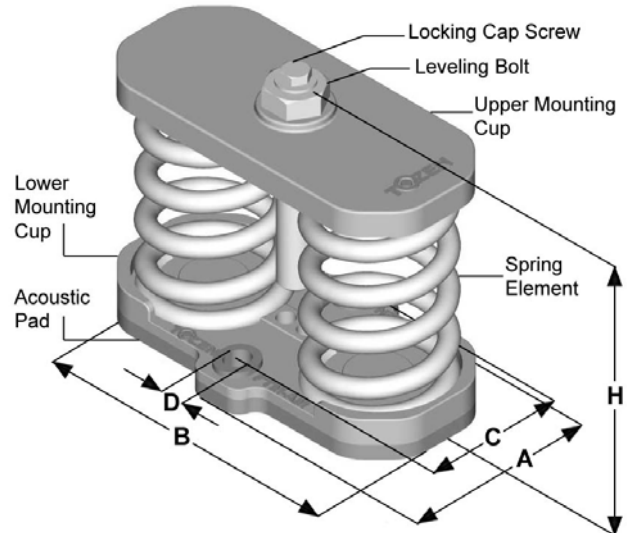
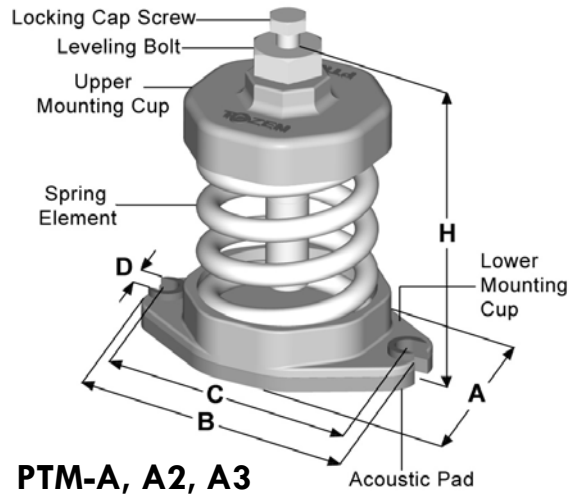
**PTM-A FLOOR MOUNTING SINGLE SPRING ISOLATOR**  
**PTM-AM HEAVY LOADING MULTIPLE SPRING ISOLATOR**

**DESCRIPTION :** TOZEN Model PTM-A & PTM-AM series isolators are unboxed, spring, vibration isolators, designed for high deflection. The PTM-A employs the use of a single spring element, while the PTM-AM employs multiple spring elements for heavier applications. These laterally stable steel spring isolators are constructed with a leveling device at the top of the isolator and a non-skid acoustical pad at the bottom. Both models are constructed with upper and lower ductile cast iron holding cups to hold the spring element. In addition, PTM-A & PTM-AM have a mounting base plate to allow the isolator to be bolted to a structure and a resilient washer as part of the non-skid acoustical pad. The resilient washer helps prevent the transmission of noise and vibration from the base plate and mounting bolt to the structure.

The design of the spring elements, within the isolators, complies with established standard JIS B2704, for semi-permanent use. To assure lateral stability, the outside diameter of the spring element is greater than 80% of the height of the compressed spring element when at rated load. All the spring elements are designed to provide a minimum of overloading capacity of 50%.

PTM-A & PTM-AM series vibration isolator are available in the standard deflections at 25 mm, and also available in deflections of 50 and 75 mm. Load capacity of the PTM-A isolators range from 25 to 1,400 Kgs (55 to 3080 lbs) and up to 5,600 Kgs (12320 lbs.) for PTM-AM isolators.

Tozen PTM-A & PTM-AM series of spring isolators are highly effective in the control of both high and low frequency vibrations produced by mechanical equipment, such as Reciprocating Air or Refrigeration Compressors, Pumps, Air Conditioning and Air Handling Equipment, Centrifugal and Axial Fans, Internal Combustion Engines and similar types of equipment.



**Note :** xxx = Rated Capacity  
 PTM-AM3 is steel fabricated model.

**APPLICATION :** PTM-A & PTM-AM series spring isolators are recommended for use in isolating floor mounted sources of noise and vibration located near critical quiet areas.

PTM-A series spring isolators are typically used to reduce the transmission of noise and vibration from low speed mechanical equipment into a building structure.

PTM-A & AM series spring isolators can be used in a wide range of applications involving the isolation of mechanical equipment, such as Reciprocating Air or Refrigeration Compressors, Close Coupled and Base Mounted Pumps, Package Air Handling and Refrigeration Equipment, Centrifugal Fans, Internal Combustion Engines and similar equipment.

**SPECIFICATION :**

The vibration isolators shall be free standing, with laterally stable steel spring elements, without housings, snubbers or guides. The isolators shall be constructed with the ductile cast iron upper mounting cup and the ductile cast iron lower mounting cup to hold the spring element, and a non-skid acoustical pad is attached under the lower cup. The isolators shall be provided with an adjusting bolt, cap screw and washer in top of the isolator for leveling and attachment to the equipment. The spring elements of the isolator shall have an outside diameter greater than 80% of the height of the compressed spring element at rated load. All spring elements shall be designed to provide a minimum overloading capacity of 50%.

The isolators shall be selected to provide operating static deflection shown on the Vibration Isolation Schedule or as indicated by the project specifications. Isolators shall be color coded or otherwise identified to indicate load capacity.

**PTM-A, AM**

**TYPE 25 mm. DEFLECTION SINGLE & MULTIPLE SPRING VIBRATION ISOLATOR**

MODEL	RATED CAPACITY		SPRING CONSTANT (kg/mm)	SPRING ELEMENT			OPERATING HEIGHT (H)	DIMENSION (mm)				LOCKING CAP SCREW (LS)	LEVELING BOLT (LB)
	(kgs)	(Lbs)		SPRING COLOR	OD (mm)	FREE HEIGHT (mm)		A	B	C	D		
PTM-A-25S	25	55	1.0	WHITE	50	80	120	61	107	89	10	M10x32	M16x70
PTM-A-35S	35	77	1.4	YELLOW									
PTM-A-50S	50	110	2.0	ORANGE									
PTM-A-80S	80	176	3.2	VIOLET									
PTM-A-120S	120	264	4.8	RED									
PTM-A-175ES	175	385	7.0	SILVER									
PTM-A-225ES	225	495	9.0	BROWN									
PTM-A-200M	200	440	8.0	VIOLET	75	100	150	88	136	117	13	M12x43	M22x80
PTM-A-300M	300	660	12.0	RED									
PTM-A-450M	450	990	18.0	GREEN									
PTM-A-600EM	600	1320	24.0	SILVER									
PTM-A-825EM	825	1815	33.0	BROWN									
PTM-A-1100EM	1100	2420	44.0	BLUE									
PTM-A-1400EM	1400	3080	56.0	BLUE+BROWN									
PTM-AM-1652EM	1650	3630	66.0	BROWN	75	100	144	112	198	75	14x18	M12x43	M22x80
PTM-AM-2202EM	2200	4840	88.0	BLUE									
PTM-AM-2802EM	2800	6160	112.0	BLUE+BROWN									
PTM-AM-3304EM	3300	7260	132.0	BROWN	75	100	152	197	197	161	14x18	M16x45	M30x90
PTM-AM-4404EM	4400	9680	176.0	BLUE									
PTM-AM-5604EM	5600	12320	224.0	BLUE+BROWN									

NOTE-1: All springs are laterally stable and suitable for free standing application. (Outside diameter > 80% of deflection height)

NOTE-2: All springs are designed with additional travel to solid at least 50% of rated load.

NOTE-3: Please refer to relevant brochure or our technical division for greater deflection and loading.

## PTM-A2, AM2

### TYPE 50 mm. DEFLECTION SINGLE & MULTIPLE SPRING VIBRATION ISOLATOR

MODEL	RATED CAPACITY		SPRING CONSTANT (kg/mm)	SPRING ELEMENT			OPERATING HEIGHT (H)	DIMENSION (mm)				LOCKING CAP SCREW (LS)	LEVELING BOLT (LB)
	(kgs)	(Lbs)		SPRING COLOR	OD (mm)	FREE HEIGHT (mm)		A	B	C	D		
PTM-A2-25S	25	55	0.5	WHITE	75	120	170	88	136	117	13	M12x43	M22x80
PTM-A2-35S	35	77	0.7	YELLOW									
PTM-A2-50S	50	110	1.0	ORANGE									
PTM-A2-80ES	80	176	1.6	VIOLET									
PTM-A2-125ES	125	275	2.5	RED									
PTM-A2-175ES	175	385	3.5	SILVER									
PTM-A2-250ES	250	550	5.0	BROWN									
PTM-A2-175EM	175	385	3.5	ORANGE	90	145	195	101	155	130	13	M12x43	M22x115
PTM-A2-245EM	245	539	4.9	VIOLET									
PTM-A2-350EM	350	770	7.0	RED									
PTM-A2-525EM	525	1155	10.5	GREEN									
PTM-A2-750EM	750	1650	15.0	SILVER									
PTM-A2-1050EM	1050	2310	21.0	SILVER+BROWN									
PTM-AM2-1502EM	1500	3300	30.0	SILVER	90	145	189	130	230	92	14x18	M12x43	M22x80
PTM-AM2-2102EM	2100	4620	42.0	SILVER+BROWN									
PTM-AM2-3004EM	3000	6600	60.0	SILVER			196	244	244	203	14x18	M16x45	M30x90
PTM-AM2-4204EM	4200	9240	84.0	SILVER+BROWN									

NOTE-1: All springs are laterally stable and suitable for free standing application. (Outside diameter > 80% of deflection height)

NOTE-2: All springs are designed with additional travel to solid at least 50% of rated load.

NOTE-3: Please refer to relevant brochure or our technical division for greater deflection and loading.

## PTM-A3, AM3

### TYPE 75 mm. DEFLECTION SINGLE & MULTIPLE SPRING VIBRATION ISOLATOR

MODEL	RATED CAPACITY		SPRING CONSTANT (kg/mm)	SPRING ELEMENT			OPERATING HEIGHT (H)	DIMENSION (mm)				LOCKING CAP SCREW (LS)	LEVELING BOLT (LB)
	(kgs)	(Lbs)		SPRING COLOR	OD (mm)	FREE HEIGHT (mm)		A	B	C	D		
PTM-A3-180ES	180	396	2.4	ORANGE	90	170	220	101	155	130	13	M12x43	M22x115
PTM-A3-255ES	255	561	3.4	VIOLET									
PTM-A3-375ES	375	825	5.0	RED									
PTM-A3-555EL	555	1221	7.4	SILVER	110	190	242	121	181	149	13	M12x43	M22x115
PTM-A3-810EL	810	1782	10.8	YELLOW									
PTM-A3-1065EL	1065	2343	14.2	YELLOW+BROWN									
PTM-AM3-1112EL	1110	2442	14.8	SILVER	110	190	255	125	360	40	16	M12x43	M22x115
PTM-AM3-1622EL	1620	3564	21.6	YELLOW									
PTM-AM3-2132EL	2130	4686	28.4	YELLOW+BROWN									

NOTE-1: All springs are laterally stable and suitable for free standing application. (Outside diameter > 80% of deflection height)

NOTE-2: All springs are designed with additional travel to solid at least 50% of rated load.

NOTE-3: Please refer to relevant brochure or our technical division for greater deflection and loading.

### **INSTALLATION INSTRUCTION :**

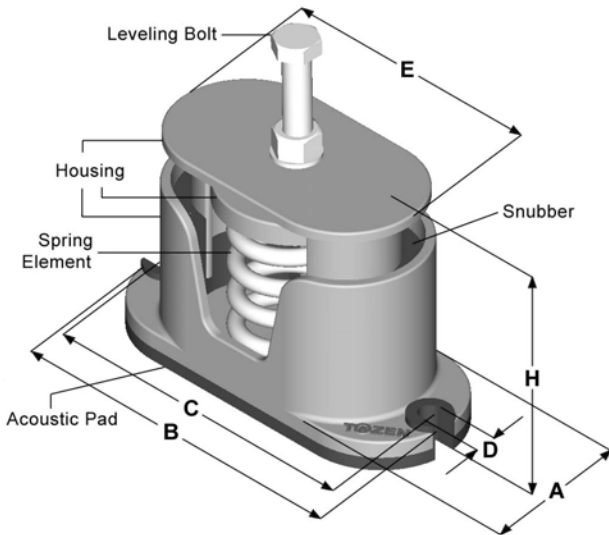
1. Block or lift up the equipment to a level so that the equipment's leg or base is 5 mm higher than isolator's operating height (see catalogue). If common base & height saving isolator bracket is used, keep 50-mm clearance between the base and floor. Maintain this height until piping installation is completed.
2. Locate the spring isolator under the hole in equipment's leg or isolator's bracket. Connect locking cap screw and washer, but do not tighten.
3. Transfer the equipment weight to the spring by taking two counter-clockwise turns on each leveling bolt around the unit until springs are compressed just enough to remove the blocks.
4. Tighten the locking cap screw to lock the assembly.

### **REMARKS :**

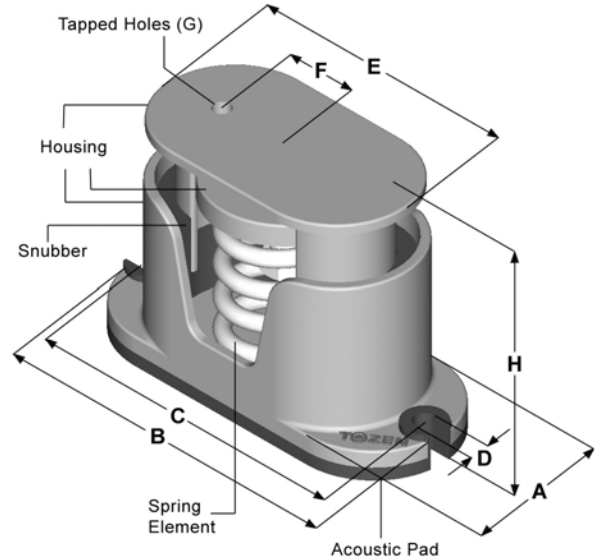
- DO NOT install the equipment on the support of a free spring. This will cause an insufficient operating height for the spring isolator when the installation is completed.
- Weight of vertical piping and valves must to supported by the suspension hangers or supports.
- Install the flexible joint at the end of the installation, following the pre-extension instruction which may specified or suggested by the flexible joint manufacturer.
- Bolting down the isolator to the floor, in most cases, is not necessary as the non-slip rubber pad or mounting cup will prevent movement. Where bolting is required, avoid a direct metal contact between bolt and mounting, to prevent transmission of noise; the bolt shank shall be clear in the hole and a rubber washer used under the bolt head. Bolts shall only be tightened a half turn more than hand tight.

**PTM-C, CH, CG HOUSED SPRING ISOLATOR**

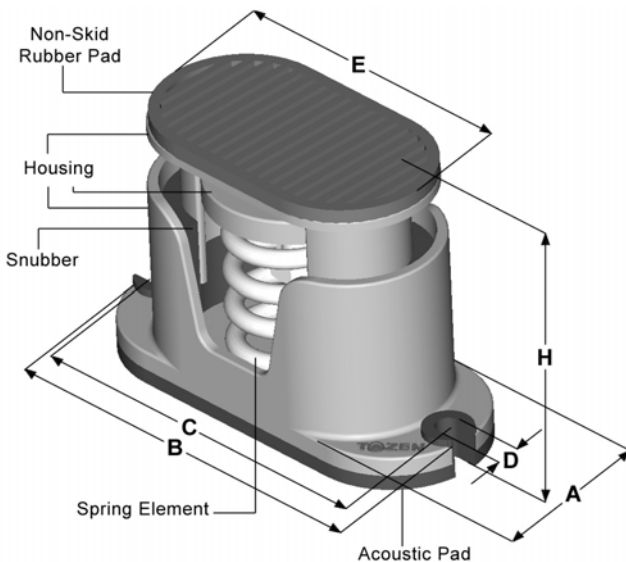
**DESCRIPTION :** TOZEN PTM-C, PTM-CH and PTM-CG series spring vibration isolators are designed and constructed for high deflection, with laterally stable spring elements and assembled into telescoping cast iron housing. Each cast iron housing is equipped with an 8 mm thick, ribbed, noise absorbing pad that is bonded to the bottom. Each isolator has an internal or external adjusting/leveling bolt as a part of the top assembly. The ribbed, noise absorbing pad has an integrated resilient washer that prevents the transmission of noise and vibration from the contact of the bolt and mounting base plate to the structure. Holes or slots are provided in all of the isolators for bolting the isolator to the structure. Model PTM-C series spring isolators are available in standard deflection of 25 and 50 mm with load capacity from 200 Kgs to 1,400 Kgs (440 to 3080 lbs). Tozen Model PTM-C spring isolators are typically used to isolate vibration produced by mechanical, industrial, or process machinery, where more damping is required and less motion can be tolerated than with free standing spring isolators.



**PTM-C, PTM-C2**



**PTM-CH, PTM-CH2**



**PTM-CG, PTM-CG2**

**APPLICATION :** TOZEN Model PTM-C spring isolators are used to isolate high and low frequency vibration generated by floor mounted mechanical equipment located in non-critical and semi-critical areas.

Model PTM-C spring isolators are typically used to isolate the vibration produced by light weight mechanical equipment having the lowest operating speed of 1,200 rpm, located on grade supported slabs, or short structural floor spans, or when the isolator to equipment connection is such that a leveling bolt can be extended above the mount and act as a leveling and attachment bolt for the supporting equipment.

Model PTM-CH isolators are available with tapped holes at the top of the loading plate for bolting the isolator to the supporting equipment. An internal leveling device is provided for height adjustments, which is accessible through the side opening by means of an open-end wrench.

Model PTM-CG isolators are available with non-skid rubber pad bonded at the top loading plate to eliminate the need for bolting down the supporting equipment. An internal leveling device is provided for height adjustment, which is accessible through the side opening by means of an open-end wrench.

**SPECIFICATION :** The vibration isolators shall be constructed with cast iron housed steel spring elements, a load cap and rubber sponge snubbers. The snubbers shall be designed to stabilize the isolator and prevent metal on metal contact within the top or bottom of the housed section. The top loading plate shall be constructed with a leveling bolt and lock nut.

The housing's bottom shall be bonded to an 8 mm thick, ribbed, rubber pad and shall be slotted or drilled to allow for the bolting of the isolator to the supporting structure.

Outside diameter of the spring elements shall be greater than 80% of the compressed height of the spring element at the rated load. All spring elements shall be designed to provide a minimum 50% overload capacity.



Spring shall be selected to provide operating static deflections shown on the Vibration Isolation Schedule or as indicated on the project specifications. Springs shall be color coded or otherwise identified to indicate load capacity.

Vibration isolators shall be Model PTM-C as manufactured by Tozen Sangyo Co.,Ltd.

## PTM-C, CH, CG

### TYPE 25 mm. DEFLECTION ANTI-VIBRATION MOUNTING

(mm)

MODEL	RATED CAPACITY		SPRING CONSTANT (Kg/mm)	SPRING COLOR	OPERATING HEIGHT (H)			(A)	(B)	SLOT PITCH (C)	SLOT HOLE (D)	TOP PLATE LENGTH (E)	CH TYPE		C-TYPE LEVELING BOLT (LB)	
	(Kgs)	(Lbs)			C TYPE	CH TYPE	CG TYPE						(F)	(G)		
PTM-C-200M	200	440	8	VIOLET												
PTM-C-300M	300	660	12	RED												
PTM-C-450M	450	990	18	GREEN												
PTM-C-600EM	600	1320	24	SILVER	145	162	170	94	216	194	13	162	45	M12	M16	
PTM-C-825EM	825	1815	33	BROWN												
PTM-C-1100EM	1100	2420	44	BLUE												
PTM-C-1400EM	1400	3080	56	BLUE+BROWN												

## PTM-C2, CH2, CG2

### TYPE 50 mm. DEFLECTION ANTI-VIBRATION MOUNTING

(mm)

MODEL	RATED CAPACITY		SPRING CONSTANT (Kg/mm)	SPRING COLOR	OPERATING HEIGHT (H)			(A)	(B)	SLOT PITCH (C)	SLOT HOLE (D)	TOP PLATE LENGTH (E)	CH TYPE		C-TYPE LEVELING BOLT (LB)	
	(Kgs)	(Lbs)			C2 TYPE	CH2 TYPE	CG2 TYPE						(F)	(G)		
PTM-C2-175EM	175	385	3.5	ORANGE												
PTM-C2-245EM	245	539	4.9	VIOLET												
PTM-C2-350EM	350	770	7	RED												
PTM-C2-525EM	525	1155	10.5	GREEN	185	202	210	110	254	229	16	195	45	M12	M16	
PTM-C2-750EM	750	1650	15	SILVER												
PTM-C2-1050EM	1050	2310	21	SILVER+BROWN												

NOTE-1: All springs are free standing and laterally stable. (Outside diameter do not less than 0.8 times of compressed height.)

NOTE-2: Please refer to relevant brochure of factory for greater deflection and loading.

NOTE-3: PTM-C type External Leveling Bolt (LB) is suitable for maximum 25 mm. bracket or base thickness, please specify for equipment base thicker than 25 mm.

### INSTALLATION INSTRUCTION :

A. for PTM-C (External level adjusted) spring isolators

1. Take out the leveling bolt and lock nut from the top of the isolator.
2. Lift or block up the equipment's leg or isolator bracket to 5mm higher isolators operating height (see catalogue) and slide the isolators into position. Put the leveling bolt & lock nut back into position.
3. Transfer the equipment weight to the spring by taking two clockwise turns on each leveling bolt around the unit until the springs are compressed just enough to remove blocks.
4. Tighten the lock nut to lock the assembly.

B. For PTM-CH & PTM-CG (Internal level adjusted) spring isolators

1. Check that the internal leveling nut is adjusted up to underside of the top plate.
2. Lift or block up the equipment to 5mm higher than isolator's operating height (see catalogue) and slide the isolators into position and adjust the leveling nut until the top plate is in contact with equipment base. Insert fastening screws (if used) through the equipment base into top of the mounting and tighten.
3. Transfer the equipment weight to the spring by taking two anti-clockwise turns on each leveling bolt around the unit until springs are compressed just enough to remove blocks.

### REMARKS :

- a. When the equipment is not subject to rise to the required height, height saving bracket may be attached to the equipment. The height of bracket connection from the bottom of the base shall be 50mm less than the isolator's operating height or to keep a 50mm clearance between the ground and equipment.
- b. DO NOT install the equipment on the support of free spring; it would cause an insufficient operating height for the spring isolator when the installation is completed.
- c. Weight of vertical piping and valves shall be supported by the suspension hangers or other supports.
- d. Install the flexible joint at the completion of the installation, following the pre-extension instructions which may be specified or suggested by the flexible joint manufacturer.
- e. Where bolting is required, avoid a direct metal contact between bolt and mounting, to prevent transmission of acoustical frequencies; the bolt shank shall be clear in the hole and a rubber washer used under the bolt head. Bolts shall only be tightened a half turn more than hand tight.

## PTM-D, D2, D3 (CARBON STEEL TYPE) RESTRAINED SINGLE AND MULTIPLE SPRING ISOLATOR

**DESCRIPTION :** TOZEN PTM-D series vibration isolators consist of free standing laterally stable steel springs assembled into welded steel housing assemblies fabricated to limit vertical movement of the isolated equipments when if equipment loads are reduced or if the equipments are subjected to large external forces. Spring elements are complete with an internal adjusting and leveling bolt. Tapped holes are provided at the top load plate for bolting to supported equipment. A 8mm thick non-skid noise absorbing rubber pad is bonded at the bottom plate with holes for bolting to the structure. All the spring elements are comply to JIS 2704 for semi-permanent use. To assure lateral stability, outside diameter of the spring elements do not less than 0.8 times of the compressed height of the spring at rated load. All the spring are designed to provide a minimum of 50% overload capacity.

PTM-D series vibration isolator are shipped with standard deflections of 25mm, and available up to 75mm, with load capacities from 175 Kgs to 8,400 Kgs. Model PTM-D spring isolators are recommended for the isolation of vibration produced by equipment carrying a large fluid load which may be drained, such as boilers and chillers, and for the isolation of cooling towers, air cooled condensers, etc, where motion due to wind loads must be minimized.

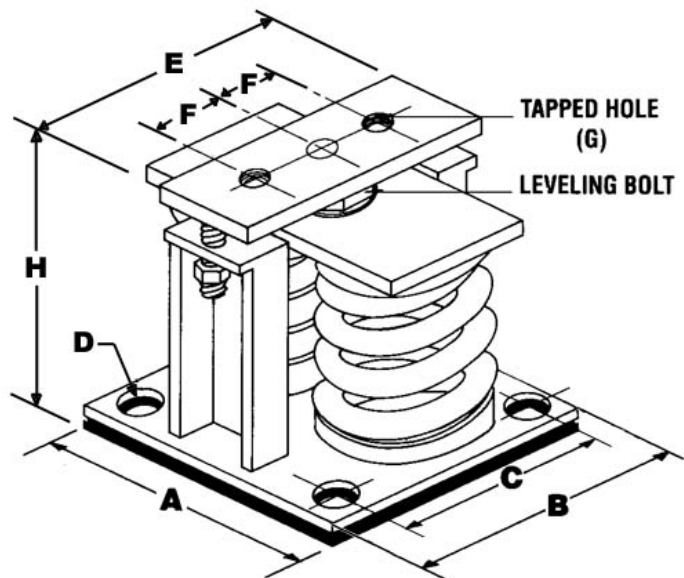
**APPLICATION :** Model PTM-D mounts are typically used to reduce the transmission of noise and vibration into supporting structures from equipments carrying a large fluid load that may be drained, such as boilers and for cooling towers, which also require hold down for wind loads.

**SPECIFICATION :** Vibration isolators for equipment which is subject to load vibrations and large external or torquing forces shall consist of laterally stable steel springs assembled into a welded steel housing assembly designed to limit vertical movement of the supported equipment.

Housing assembly shall be of fabricated steel members and consist of a load transfer plate at the top complete with tapped holes, adjusting and leveling bolts, vertical restraints, isolation washers and a bottom plate with non-skid noise isolation pad and holes provided for anchoring to supporting structure.

Spring elements shall have a outside diameter not less than 0.8 times to the compressed height of the spring rated load. All springs shall be designed to provide a minimum of. 50% overload capacity.

Vibration isolators shall be Model PTM-D, as manufactured by Tozen Sangyo Co., Ltd.



### INSTALLATION INSTRUCTION

1. Check that the internal leveling nut is adjusted up to underside of the top plate.
2. Lift or block up the equipment to 5mm higher than isolator's operating height (see catalogue) and slide the isolators into position and adjust the leveling nut until the top plate is in contact with equipment base. Insert fastening screws (if used) through the equipment base into top of the mounting and tighten.
3. Check alignment of the base so that restraining bolts are central with clearance holes in the restraining bracket.
4. Transfer the equipment weight to the spring by taking two clockwise turns on each leveling bolt around the unit until springs are compressed just enough to remove blocks.
5. Adjust restraining nuts to give 2-3mm clearance between the resilient washer and the underside of the restraining bracket. Check the leveling again after the system is filled with water.
6. Tighten the lock nut to lock the assembly.

### REMARKS

- a. When the equipment are not subject to raise to the required height, height saving bracket may be attached to the equipment. The height of bracket connection from the bottom of the base shall be 50mm less than the isolator's operating height or to keep a 50mm clearance between the ground and equipment.
- b. DON'T install the equipment on the support of free spring, it would cause an insufficient operating height for the spring isolator when the installation is completed.
- c. Weight of vertical piping and valves shall be taken over by the suspension hangers or support.
- d. Install the flexible joint at final, follow the pre-extension instruction which may specified or suggested by the flexible joint manufacturer.
- e. Where bolting is required, avoid a direct metal contact between bolt and mounting, to prevent transmission of acoustical frequencies; the bolt shank shall be clear in the hole and a rubber washer used under the bolt head. Bolts shall only be tightened a half turn more than hand tight.

## PTM-D (CARBON STEEL TYPE) 25mm DEFLECTION RESTRAINED SPRING ISOLATOR

MODEL	RATED CAPACITY		MOUNT CONSTANT (Kg/mm)	SPRING COLOR	OPERATING HEIGHT (H)	DIMENSION (mm)						
	(Kgs)	(Lbs)				A	B	C	D	E	F	G
PTM-D-451M	450	990	18	GREEN	160	100	184	154	16	184	40	12
PTM-D-601EM	600	1320	24	SILVER								
PTM-D-826EM	825	1815	33	BROWN								
PTM-D-1101EM	1100	2420	44	BLUE								
PTM-D-1401EM	1400	3080	56	BLUE+BROWN								
PTM-D-1652EM	1650	3630	66	BROWN	180	200	195	155	18	195	40	16
PTM-D-2202EM	2200	4840	88	BLUE								
PTM-D-2802EM	2800	6160	112	BLUE+BROWN								
PTM-D-3304EM	3300	7260	132	BROWN	195	170	280	240	20	280	45	16
PTM-D-4404EM	4400	9680	176	BLUE								
PTM-D-5604EM	5600	12320	224	BLUE+BROWN								
PTM-D-4956EM	4950	10890	198	BROWN	205	255	280	230	20	280	65	16
PTM-D-6606EM	6600	14520	264	BLUE								
PTM-D-8406EM	8400	18480	336	BLUE+BROWN								

NOTE-1: All springs are free standing and laterally stable. (Outside diameter do not less 0.8 times of compressed height)

NOTE-2: All springs are designed to provide additional travel to solid of at least 50% rated load.

NOTE-3: Please refer to relevant brochure or factory for greater deflection and loading.

## PTM-D2 (CARBON STEEL TYPE) 50mm DEFLECTION RESTRAINED SPRING ISOLATOR

MODEL	RATED CAPACITY		MOUNT CONSTANT (Kg/mm)	SPRING COLOR	OPERATING HEIGHT (H)	DIMENSION (mm)						
	(Kgs)	(Lbs)				A	B	C	D	E	F	G
PTM-D2-176	175	385	3.5	ORANGE	205	100	200	170	16	200	40	12
PTM-D2-246	245	539	4.9	VIOLET								
PTM-D2-351	350	770	7	RED								
PTM-D2-526	525	1155	10.5	GREEN								
PTM-D2-751	750	1650	15	SILVER								
PTM-D2-1051	1050	2310	21	SILVER+BROWN	225	230	210	170	18	210	40	16
PTM-D2-1502	1500	3300	30	SILVER								
PTM-D2-2102	2100	4620	42	SILVER+BROWN								
PTM-D2-3004	3000	6600	60	SILVER	240	200	310	270	20	310	50	16
PTM-D2-4204	4200	9240	84	SILVER+BROWN								
PTM-D2-4506	4500	9900	90	SILVER	250	300	310	260	20	310	65	16
PTM-D2-6306	6300	13860	126	SILVER+BROWN								

NOTE-1: All springs are free standing and laterally stable.

NOTE-2: All springs are designed to provide additional travel to solid of at least 50% rated load.

NOTE-3: Please consult the representatives for a complete vibration control design.

## PTM-D3 (CARBON STEEL TYPE) 75mm DEFLECTION RESTRAINED SPRING ISOLATOR

MODEL	RATED CAPACITY		MOUNT CONSTANT (Kg/mm)	SPRING COLOR	OPERATING HEIGHT (H)	DIMENSION (mm)						
	(Kgs)	(Lbs)				A	B	C	D	E	F	G
PTM-D3-180ES	180	396	2.4	ORANGE	240	100	220	180	18	220	50	M16
PTM-D3-255ES	255	561	3.4	VIOLET								
PTM-D3-375ES	375	825	5	RED								
PTM-D3-555EL	555	1221	7.4	SILVER	274	125	245	205	18	245	40	M16
PTM-D3-810EL	810	1782	10.8	YELLOW								
PTM-D3-1065EL	1065	2343	14.2	YELLOW+BROWN								
PTM-D3-1112EL	1110	2442	14.8	SILVER	290	282	245	205	18	245	40	M16
PTM-D3-1622EL	1620	3564	21.6	YELLOW								
PTM-D3-2132EL	2130	4686	28.4	YELLOW+BROWN								

NOTE-1: All springs are free standing and laterally stable.

NOTE-2: All springs are designed to provide additional travel to solid of at least 50% rated load.

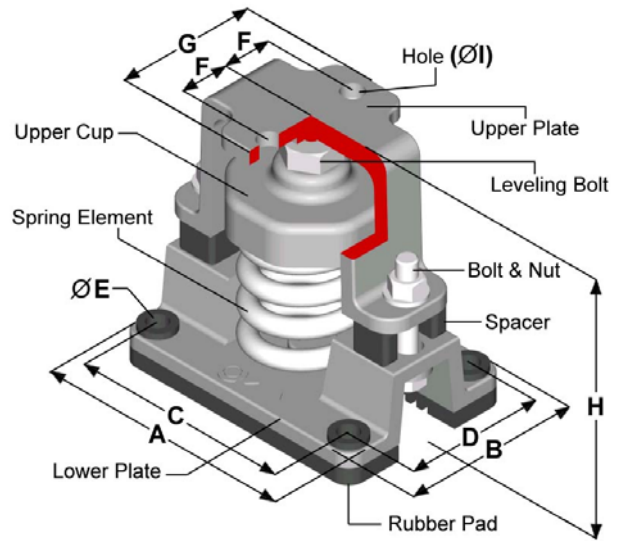
NOTE-3: Please consult the representatives for a complete vibration control design.

# PTM-D (DUCTILE IRON TYPE) RESTRAINED SINGLE AND MULTIPLE SPRING ISOLATOR

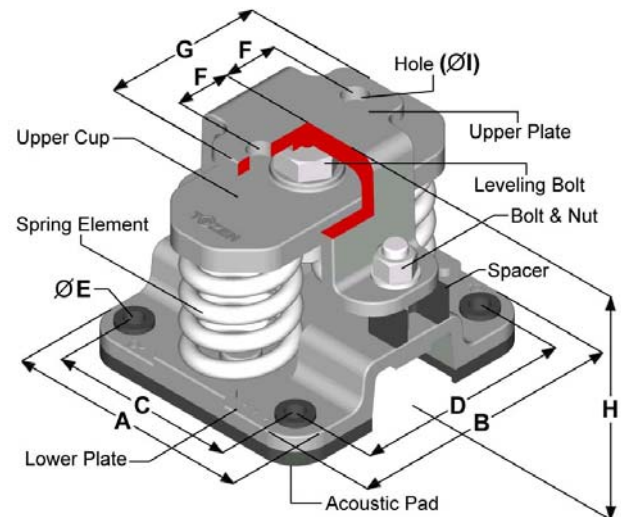
**DESCRIPTION :** TOZEN PTM-D series vibration isolators consist of free standing laterally stable steel springs assembled into ductile iron housing assemblies fabricated to limit vertical movement of the isolated equipments when if equipment loads are reduced or if the equipments are subjected to large external forces. Spring elements are complete with an internal adjusting and leveling bolt. Holes are provided at the upper plate for bolting to supported equipment. A 10mm thick non-skid noise absorbing rubber pad is bonded at the bottom plate with holes for bolting to the structure. All the spring elements are comply to JIS 2704 for semi-permanent use. To assure lateral stability, outside diameter of the spring elements do not less than 0.8 times of the compressed height of the spring at rated load. All the spring are designed to provide a minimum of 50% overload capacity.

PTM-D series vibration isolator are shipped with standard deflections of 25 and 50 mm, and available up to 50mm, with load capacities from 450 Kgs to 5,600 Kgs. Model PTM-D spring isolators are recommended for the isolation of vibration produced by equipment carrying a large fluid load which may be drained, such as boilers and chillers, and for the isolation of cooling towers, air cooled condensers, etc, where motion due to wind loads must be minimized.

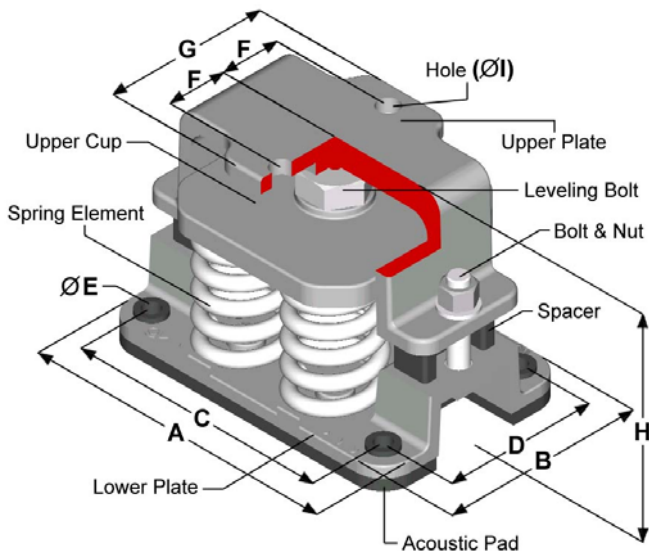
**APPLICATION :** Model PTM-D mounts are typically used to reduce the transmission of noise and vibration into supporting structures from equipments carrying a large fluid load that may be drained, such as boilers and for cooling towers, which also require hold down for wind loads.



**PTM-D-451M, 601EM, 826EM, 1101EM, 1401EM  
PTM-D2-176, 246, 351, 526, 751, 1051**



**PTM-D-1652EM, 2202EM, 2802EM  
PTM-D2-1502, 2102**



**PTM-D-3304EM, 4404EM, 5604EM  
PTM-D2-3004, 4204**

**SPECIFICATION :** Vibration isolators for equipment which is subject to load vibrations and large external or torquing forces shall consist of laterally stable steel springs assembled into a ductile iron housing assembly designed to limit vertical movement of the supported equipment.

Housing assembly shall be of ductile iron members and consist of a load transfer plate at the top complete with holes, adjusting and leveling bolts, vertical restraints, isolation washers and a bottom plate with non-skid noise isolation pad and holes provided for anchoring to supporting structure.

Spring elements shall have a outside diameter not less than 0.8 times to the compressed height of the spring rated load. All springs shall be designed to provide a minimum of . 50% overload capacity.

Vibration isolators shall be Model PTM-D, as manufactured by Tozen Sangyo Co., Ltd.

\* These images are sectioned for better appearance.

## PTM-D (DUCTILE IRON TYPE) 25mm DEFLECTION RESTRAINED SPRING ISOLATOR

MODEL	RATED CAPACITY		MOUNT CONSTANT (Kg/mm)	SPRING COLOR	OPERATING HEIGHT (H)	DIMENSION (mm)							
	(Kgs)	(Lbs)				A	B	C	D	E	F	G	I
PTM-D-451M	450	990	18	GREEN	170	172	121	137	86	16	30	88	14
PTM-D-601EM	600	1320	24	SILVER									
PTM-D-826EM	825	1815	33	BROWN									
PTM-D-1101EM	1100	2420	44	BLUE									
PTM-D-1401EM	1400	3080	56	BLUE+BROWN									
PTM-D-1652EM	1650	3630	66	BROWN	170	180	200	136	156	20	40	118	18
PTM-D-2202EM	2200	4840	88	BLUE									
PTM-D-2802EM	2800	6160	112	BLUE+BROWN									
PTM-D-3304EM	3300	7260	132	BROWN	185	255	167	211	123	20	48.5	135	18
PTM-D-4404EM	4400	9680	176	BLUE									
PTM-D-5604EM	5600	12320	224	BLUE+BROWN									

## PTM-D2 (DUCTILE IRON TYPE) 50mm DEFLECTION RESTRAINED SPRING ISOLATOR

MODEL	RATED CAPACITY		MOUNT CONSTANT (Kg/mm)	SPRING COLOR	OPERATING HEIGHT (H)	DIMENSION (mm)							
	(Kgs)	(Lbs)				A	B	C	D	E	F	G	I
PTM-D2-176	175	385	3.5	ORANGE	210	190	130	152	95	16	38	106	16
PTM-D2-246	245	539	4.9	VIOLET									
PTM-D2-351	350	770	7	RED									
PTM-D2-526	525	1155	10.5	GREEN									
PTM-D2-751	750	1650	15	SILVER									
PTM-D2-1051	1050	2310	21	SILVER+BROWN	210	232	196	187	152	20	42	120	16
PTM-D2-1502	1500	3300	30	SILVER									
PTM-D2-2102	2100	4620	42	SILVER+BROWN									
PTM-D2-3004	3000	6600	60	SILVER	220	300	200	260	162	20	66.5	170	20
PTM-D2-4204	4200	9240	84	SILVER+BROWN									

NOTE-1: All springs are free standing and laterally stable. (Outside diameter do not less 0.8 times of compressed height)

NOTE-2: All springs are designed to provide additional travel to solid of at least 50% rated load.

NOTE-3: Please refer to relevant brochure or factory for greater deflection and loading.

### INSTALLATION INSTRUCTION

1. Check that the internal leveling nut is adjusted up to underside of the upper plate.
2. Lift or block up the equipment to 5mm higher than isolator's operating height (see catalogue) and slide the isolators into position and adjust the leveling nut until the upper plate is in contact with equipment base. Insert fastening screws (if used) through the equipment base into top of the mounting and tighten.
3. Check alignment of the base so that restraining bolts are central with clearance holes in the restraining bracket.
4. Transfer the equipment weight to the spring by taking two counter-clockwise turns on each leveling bolt around the unit until springs are compressed just enough to remove blocks.
5. Adjust restraining nuts to give 2-3mm clearance between the restrain washer and the underside of the restraining bracket. Check the leveling again after the system is filled with water.
6. Tighten the lock nut to lock the assembly.

### REMARKS

- a. When the equipment are not subject to raise to the required height, height saving bracket may be attached to the equipment. The height of bracket connection from the bottom of the base shall be 50mm less than the isolator's operating height or to keep a 50mm clearance between the ground and equipment.
- b. DON'T install the equipment on the support of free spring, it would cause an insufficient operating height for the spring isolator when the installation is completed.
- c. Weight of vertical piping and valves shall be taken over by the suspension hangers or support.
- d. Install the flexible joint at final, follow the pre-extension instruction which may specified or suggested by the flexible joint manufacturer.
- e. Where bolting is required, avoid a direct metal contact between bolt and mounting, to prevent transmission of acoustical frequencies; the bolt shank shall be clear in the hole and a rubber washer used under the bolt head. Bolts shall only be tightened a half turn more than hand tight.

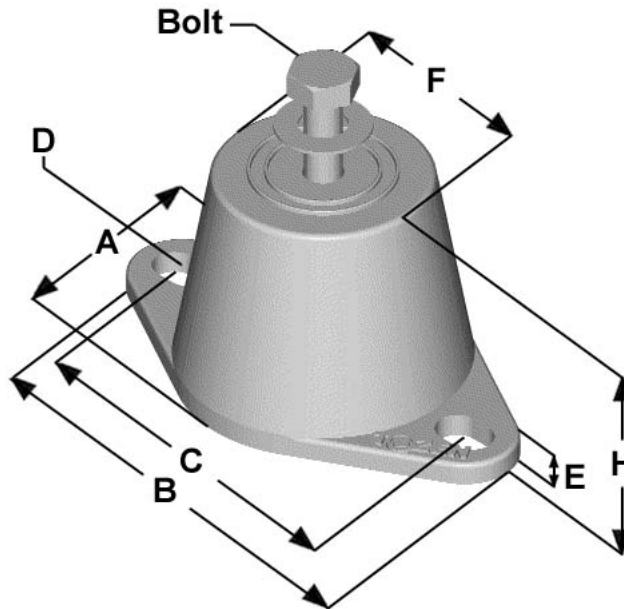
## PTM-GP FLOOR MOUNTED RUBBER VIBRATION ISOLATOR

**DESCRIPTION :** TOZEN Model PTM-GP vibration isolator are one-piece mounted neoprene with one cast-in load transfer steel plate at the top and base-plate at the bottom. The rubber is loaded in both shear and compression to provide the desirable straight line rubber-in-shear deflection curves as well as overload protection. The rubber-ribbed baseplate provides skid resistance and need not be bolted to the floor on most installations. The standard neoprene rubber is oil resistant and had been designed to operate within the strain limits of the isolator to provide the maximum isolation and longest expectancy. Model PTM-GP is available in 9 sizes with load capacity from 30 Kgs to 450 Kgs. Standard static deflection of PTM-GP is 8-10mm.

**APPLICATION :** TOZEN PTM-GP rubber floor mounted can be used to isolate noise and high frequency vibration generated by mechanical equipments located on a grade supported structural slab or pier. Model PTM-GP is recommended for the isolation of vibration produced by small pumps, vent sets, low pressure packaged air handling units, etc., and usually selected when first cost must be minimized.

**SPECIFICATION :** Vibration isolators shall be moulded from neoprene or oil resistant synthetic rubber. Rubber isolator shall incorporated with a cast-in-top steel load transfer plate in the load surface for bolting to the supported equipment and skid resistant baseplate with holes provided for anchoring to supporting structure.

**MATERIAL :** Body — Neoprene rubber  
Inserts — Mild Steel



(mm)

MODEL	RATED CAPACITY		MARKING LOAD	DURA-METER	FREE HEIGHT (H)	(A)	(B)	(C)	(D)	(E)	(F)	Bolt
	(Kgs)	(Lbs)										
PTM-GP-30	30	66	30	40	35	40	84	60	8 x 13	5	30	M8 x 25
PTM-GP-50	50	110	50	50								
PTM-GP-75	75	165	75	60								
PTM-GP-100	100	220	100	40	50	60	104	80	9 x 16	6	45	M10 x 25
PTM-GP-150	150	330	150	50								
PTM-GP-200	200	440	200	60								
PTM-GP-250	250	550	250	40	70	87	147	117	13 x 19	7	65	M12 x 25
PTM-GP-350	350	770	350	50								
PTM-GP-450	450	990	450	60								

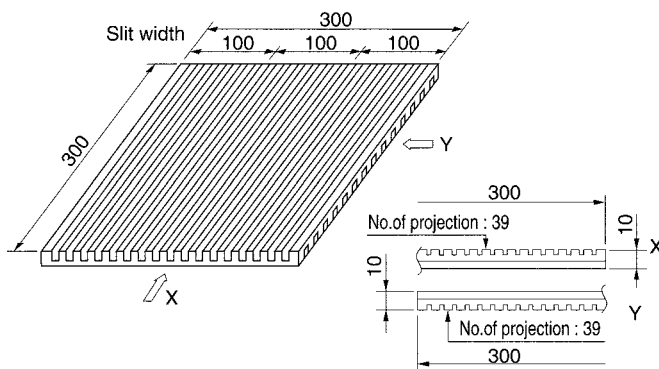
## PT-MAT VIBRATION ISOLATING RUBBER PAD

**DESCRIPTION :** TOZEN PT-MAT can be cut out to any suitable square or rectangular sizes easily to suit various mounting footings of machines or equipment for effective isolation of shock and vibration. In most cases no anchor bolting is required. Ingeniously designed having ribs of upper and lower surface arranged at right angles and optimum rubber hardness PT-MAT performs effectively against shock and vibration both laterally and vertically. At the same time noise caused by vibration is thus also reduced. In view of design and material aspects PT-MAT can withstand and absorb greater impact from various machines and equipment. It provides larger buffer capacity per unit area. Compared with other vibration isolation devices PT-MAT is the most economical type available due to mass production. Each sheet can be fully utilized without waste. The 3 different thickness (t) of PT-MAT are recommended for 2-4 kg/cm<sup>2</sup>.

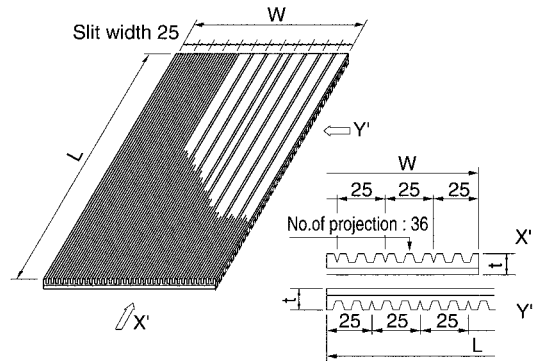
**APPLICATION :**

- Vibration isolation for equipment like packaged air handling units, pumps, etc.
- Isolation between the pipe and pipe support, etc.

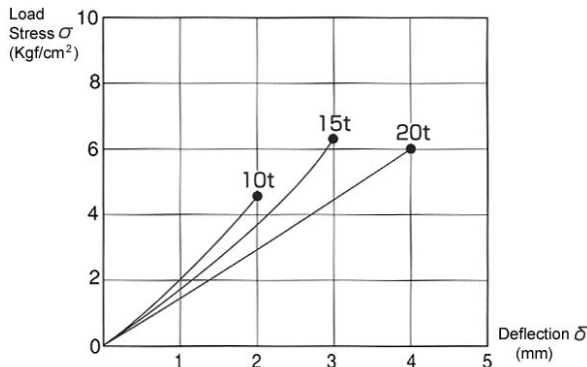
**Square Type (PT-1030)**



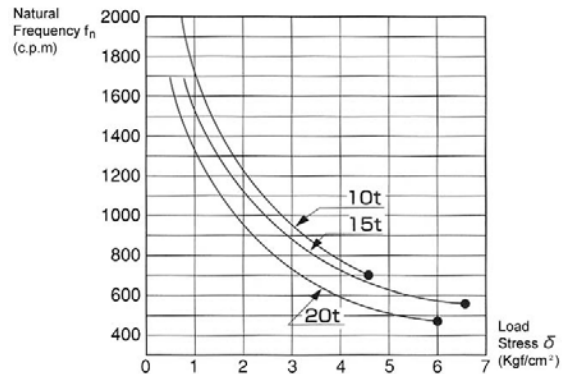
**Rectangular Type**



**• Load Stress-Deflection and Natural Frequency-Load Stress Relationship**

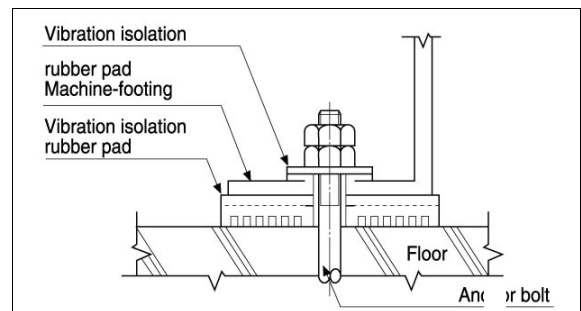


**Fig.1 Characteristic of Load Stress-Deflection**



**Fig.2 Characteristic of Natural Frequency-Load Stress**

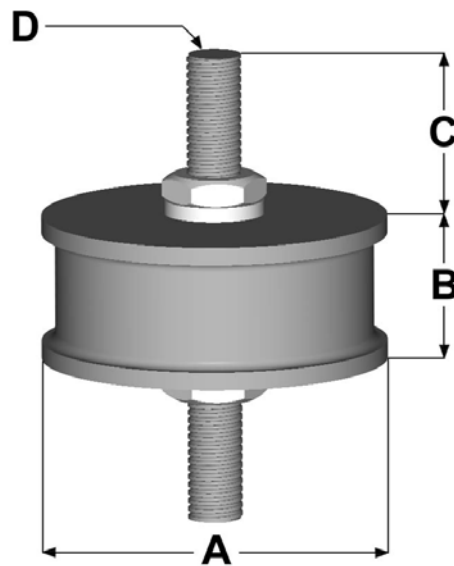
TYPE	ITEM NO.	DIMENSION (mm)			ALLOWABLE LOADING (kg/cm <sup>2</sup> )	MASS (kgs)
		t	W	L		
Square	PT-1030	10	300	300	4	0.9
Rectangular	PT-1100	10	100	1000	4	1.0
	PT-1150	10	150	1000	4	1.5
	PT-1300	10	300	1000	4	3.0
	PT-1510	15	100	1000	4	1.6
	PT-1515	15	150	1000	4	2.4
	PT-1530	15	300	1000	4	4.8
	PT-2010	20	100	1000	4	2.2
	PT-2015	20	150	1000	4	3.3
	PT-2030	20	300	1000	4	6.5



## PTM-G VIBRATION ISOLATING RUBBER MOUNT

**DESCRIPTION :** TOZEN Model PTM-G vibration isolators are one piece moulded neoprene with two cast-in load transfer steel plates incorporate with bolt, spring washer and lock nut at the top and the bottom load surface for attachment to supported equipment. The synthetic rubber compound is oil resistant and has been designed to operate within the strain limits of the isolator to provide the maximum isolation and longest expectancy.

Model PTM-G is recommended for the isolation of vibration produced by small pumps, vent sets, low pressure packaged air handling units, etc., and usually selected when first cost must be minimized.



(mm)

MODEL	PRODUCTION CODE	RATED CAPACITY		MAXIMUM STATIC DEFL.	A	B	C	D
		(Kgs)	(Lbs)					
PTM-G-20	PTM-01	20	44	2	20	15	18	M6
PTM-G-35	PTM-02	35	77	2	25	18	18	M6
PTM-G-70	PTM-04	70	154	4	35	26	22	M8
PTM-G-120	PTM-06	120	264	5	45	34	23	M8
PTM-G-175	PTM-08	175	385	6	55	40	32	M10
PTM-G-335	PTM-09	335	737	5	65	34	37	M12
PTM-G-435	PTM-10	435	957	6	75	42	37	M12
PTM-G-600	PTM-11	600	1320	8	90	50	37	M12
PTM-G-700	PTM-12	700	1540	8	110	66	46	M16
PTM-G-1500	PTM-13	1500	3300	8	150	70	51	M20



**PTH-S & PTH-S2 SPRING VIBRATION ISOLATING HANGER  
PTH-SG SPRING AND RUBBER VIBRATION ISOLATING**

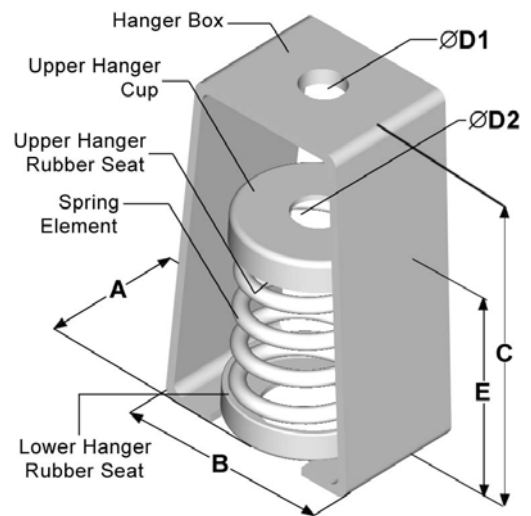
**DESCRIPTION :** TOZEN PTH-S Series vibration isolating hangers consist of a steel box incorporated with a free standing-laterally stable steel spring with load transfer steel cup and rubber washer. PTH-SG comes in series with noise absorbing hanger rubber properties of both materials. Both design permits installation in the hanger rods or at the ceiling.

The designs of the spring elements are comply to JIS 2704 for a semi-permanent use. To assure stability, outside diameter of the springs do not less than 0.8 times of the compressed height of the spring at rated load. All springs are designed to provide a minimum of 50% overload capacity. Model PTH-S spring hangers are available with 25 mm and 50 mm deflection with standard load capacity from 25 Kgs to 5,600 Kgs, while PTH-SG spring and rubber hangers are available with load capacity up to 825 Kgs. PTH-S and PTH-SG series vibration isolating hangers are recommended for the isolation of vibration produced by suspended mechanical equipment, low speed suspended fans, transformers, ductwork, piping, etc.

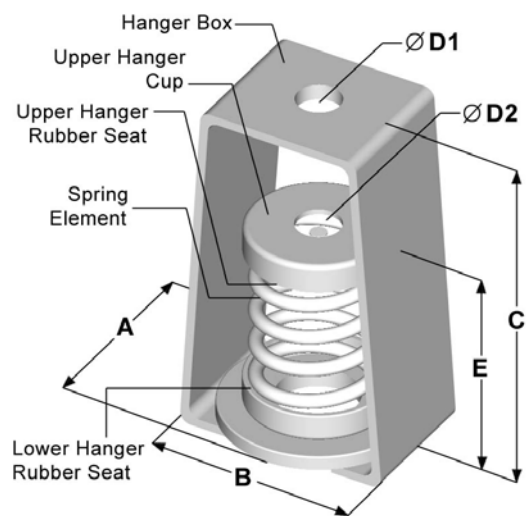
**APPLICATION :** Tozen PTH-S and PTH-SG hangers are used to isolate suspended sources of both audible and inaudible noise and vibration. Suspended mechanical equipment such as in-line fans, cabinet fans, piping and ductwork in close proximity to mechanical equipment, are typical uses of TOZEN PTH-S and PTH-SG hangers. Standard PTH-S and PTH-SG hangers are shipped fully assembled and ready for installation in threaded metal rod suspension systems. Tozen PTH-S and PTH-SG hangers can be provided with labor saving accessories for adaptation to wire or strap suspension system. Both Model PTH-S and PTH-SG hangers may be factory preloaded or provided with positioning plate for ease in erecting piping at a fixed elevation. Higher load capacities, larger deflections and 30 degree ARC capacity available.

**SPECIFICATION :** Type 1, Vibration isolators for suspended equipment, with minimum static deflection requirement exceeding of 6 mm shall be hangers consisting of a free standing, laterally stable steel spring with load transfer steel cup with rubber washer in series, assembled in a welded steel box. The spring elements shall have an outside diameter not less than 0.8 times of the compressed height of the spring at rated load. All springs shall be designed to provide a minimum of 50% overload capacity. Vibration isolating hangers shall be Model PTH-S as manufactured by Tozen Sangyo Co.,Ltd.

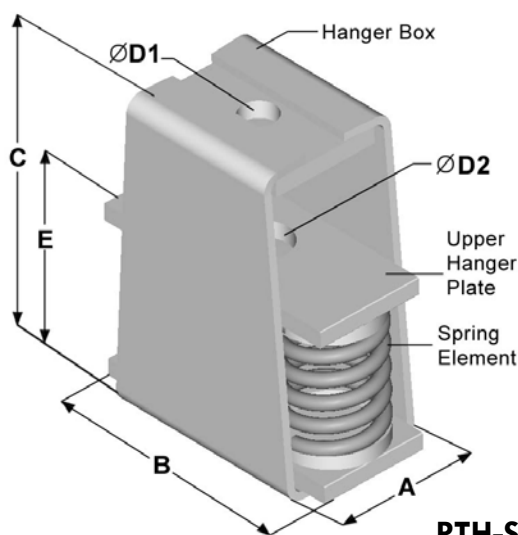
Type2, Vibration isolators for suspended equipment with minimum static deflection requirement exceeding 6 mm and where both high and low frequency vibrations are to be isolated, shall be hangers consisting of a laterally stable steel spring in series with a mounted noise absorbing rubber insert, assembled in a welded steel box . The spring elements shall have an outside diameter not less than 0.8 times of the compressed height of the spring at rated load. The combination vibration isolating hangers shall be Model PTH-SG, as manufactured by Tozen Sangyo Co., Ltd.



**PTH-S-xxxS, ES, M  
PTH-S2-xxxS, ES**

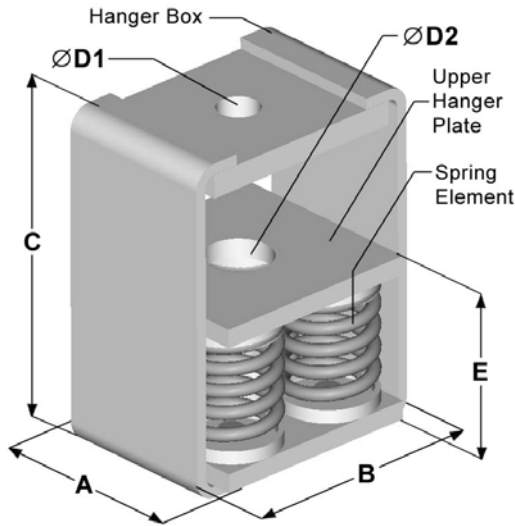


**PTH-S-xxxxEM  
PTH-S2-xxxEM**

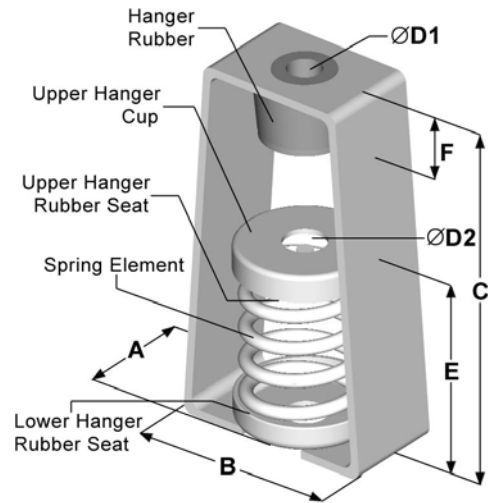


**PTH-S-xxx2EM**

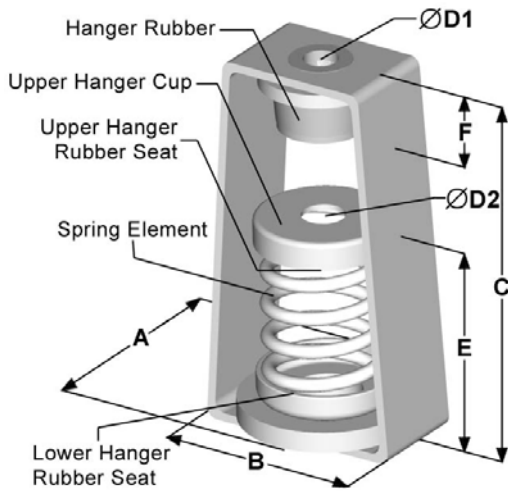
**Note :** xxx = Rated Capacity



**PTH-S-xxx4EM, PTH-S2-xxx4EM**



**PTH-SG-xxxS, PTH-SG-xxxM,  
PTH-SG2-xxxS, ES**



**PTH-SG2-xxxEM, PTH-SG-xxxEM**

## INSTALLATION INSTRUCTION

1. Consider the height and location of the hanger and prepare the upper and lower hanging rod(bolt) in same proper length.
2. Attach the upper hanging rod(bolt) to the ceiling.
3. Connect the lower hanging rod (bolt) to the hanger. Pre-compress the hanger spring element (Approx. 10 mm) by tighten a restrain nut and washer at the bottom of the hanger.
4. Attach the hanger to the upper hanging rod(bolt).
5. Attach the hanging rod(bolt) to the pipe, duct or equipment bracket.
6. Install all other hangers by repeating instruction 1-5.
7. After the pipe or equipment is filled with water, release the restrain nut. Leveling adjust the hanger by the nut at the top of the element to obtain even level installation.
8. Final check the spring hanger in a proper deflection and dont install the hanging rod(bolt) in a inclined position.

## PTH-S, PTH-S2, PTH-SG

MODEL	RATED CAPACITY		SPRING CONSTANT (Kg/mm)	SPRING COLOR	DIMENSION (mm)						
	(Kgs)	(Lbs)			A	B	C	D1	D2	E	F
<b>PTH-S TYPE 25 MM DEFLECTION</b>											
PTH-S-25S	25	55	1	WHITE							
PTH-S-35S	35	77	1.4	YELLOW							
PTH-S-50S	50	110	2	ORANGE	58	85	145	13	15	92	-
PTH-S-80S	80	176	3.2	VIOLET							
PTH-S-120S	120	264	4.8	RED							
PTH-S-175ES	175	385	7	SILVER							
PTH-S-225ES	225	495	9	BROWN	58	85	145	15	15	92	-
PTH-S-200M	200	440	8	VIOLET							
PTH-S-300M	300	660	12	RED	84	120	180	17	18	115	-
PTH-S-450M	450	990	18	GREEN							
PTH-S-600EM	600	1320	24	SILVER							
PTH-S-825EM	825	1815	33	BROWN	105	125	200	25	18	123	-
PTH-S-1100EM	1100	2420	44	BLUE							
PTH-S-1202EM	1200	2640	48	SILVER							
PTH-S-1652EM	1650	3630	66	BROWN							
PTH-S-2202EM	2200	4840	88	BLUE	124	225	278	32	32	146	-
PTH-S-2802EM	2800	6160	112	BLUE+BROWN							
PTH-S-3304EM	3300	7260	132	BROWN							
PTH-S-3604EM	3600	7920	144	BROWN+SILVER							
PTH-S-4404EM	4400	9680	176	BLUE	183	233	305	52	52	149	-
PTH-S-5604EM	5600	12320	224	BLUE+BROWN							

## PTH-S, PTH-S2, PTH-SG (continued)

MODEL	RATED CAPACITY		SPRING CONSTANT (Kg/mm)	SPRING COLOR	DIMENSION (mm)						
	(Kgs)	(Lbs)			A	B	C	D1	D2	E	F
<b>PTH-S2 TYPE 50 MM DEFLECTION</b>											
PTH-S2-25S	25	55	0.5	WHITE	84	120	210	15	18	135	-
PTH-S2-35S	35	77	0.7	YELLOW							
PTH-S2-50S	50	110	1	ORANGE							
PTH-S2-80ES	80	176	1.6	VIOLET							
PTH-S2-125ES	125	275	2.5	RED							
PTH-S2-175ES	175	385	3.5	SILVER							
PTH-S2-250ES	250	550	5	BROWN							
PTH-S2-175EM	175	385	3.5	ORANGE	105	140	255	21	24	168	-
PTH-S2-245EM	245	539	4.9	VIOLET							
PTH-S2-350EM	350	770	7	RED							
PTH-S2-525EM	525	1155	10.5	GREEN							
PTH-S2-750EM	750	1650	15	SILVER							
PTH-S2-984EM	980	2156	19.6	PINK	222	260	325	52	38	195	-
PTH-S2-1404EM	1400	3080	28	RED							
PTH-S2-2104EM	2100	4620	42	GREEN							
PTH-S2-3004EM	3000	6600	60	SILVER							
<b>PTH-SG TYPE 25 MM DEFLECTION</b>											
PTH-SG-25S	25	55	1.0	WHITE	58	85	180	16	15	92	31
PTH-SG-35S	35	77	1.4	YELLOW							
PTH-SG-50S	50	110	2.0	ORANGE							
PTH-SG-80S	80	176	3.2	VIOLET							
PTH-SG-120S	120	264	4.8	RED							
PTH-SG-175ES	175	385	7.0	SILVER							
PTH-SG-225ES	225	495	9.0	BROWN							
PTH-SG-200M	200	440	8.0	VIOLET	84	130	220	18	18	115	44
PTH-SG-300M	300	660	12	RED							
PTH-SG-450M	450	990	18	GREEN							
PTH-SG-600EM	600	1320	24	SILVER							
PTH-SG-825EM	825	1815	33	BROWN							
PTH-SG-200M	200	440	8.0	VIOLET	120	170	270	20	24	124	56
<b>PTH-SG2 TYPE 50 MM DEFLECTION</b>											
PTH-SG2-25S	25	55	0.5	WHITE	84	140	235	16	18	135	33
PTH-SG2-35S	35	77	0.7	YELLOW							
PTH-SG2-50S	50	110	1	ORANGE							
PTH-SG2-80ES	80	176	1.6	VIOLET							
PTH-SG2-125ES	125	275	2.5	RED							
PTH-SG2-175EM	175	385	3.5	ORANGE	120	160	290	18	24	168	50
PTH-SG2-245EM	245	539	4.9	VIOLET							
PTH-SG2-350EM	350	770	7	RED							
PTH-SG2-525EM	525	1155	10.5	GREEN	120	180	310	20	24	168	56
PTH-SG2-750EM	750	1650	15	SILVER							

NOTE-1: All springs have an minimum additional travel to solid equal to 50% of rated load.

NOTE-2: Please refer to relevant brochure or consult factory for greater deflection and loading.

NOTE-3: Spring constant applies to spring only.

NOTE-4: Please consult factory for pre-compressed model and 30 degree arc capacity.

**PTH-G VIBRATION ISOLATING RUBBER HANGER**

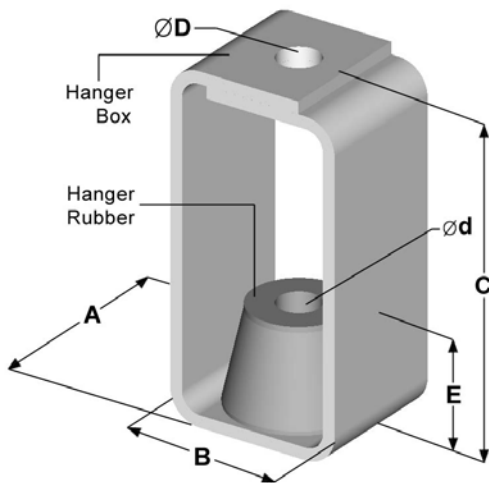
**DESCRIPTION :** TOZEN PTH-G vibration isolating rubber hangers are designed to reduce the transmission of vibration and noise produced by suspended equipment, piping and ductwork. PTH-G hangers incorporated with a noise absorbing rubber insert with cast-in load transfer plate at the top and bottom, assembled into a steel box. Ultimate design of PTH-G hanger rubbers allows greater deflection without accelerating deterioration. PTH-G hangers are available in deflection maximum up to 6 mm with capacities from 25 Kgs to 450 Kgs. PTH-G rubber hangers may be selected where first cost must be minimized. MODEL PTH-G is recommended for the isolation of vibration produced by suspended mechanical equipment, axial and exhausts fans, ductwork, piping, etc. Double deflection model PTH-GG adds another rubber element at the top of the hanger box.

**APPLICATION :** TOZEN PTH-G vibration-isolating hangers are used to isolate suspended sources of audible frequency vibration, or isolation of noise in piping and ductwork systems. Model PTH-G hangers are shipped fully assembled and ready for installation in threaded rod suspended systems. Model PTH-G hangers can be provided with labor saving accessories for adaptation to wire or strap suspension systems.

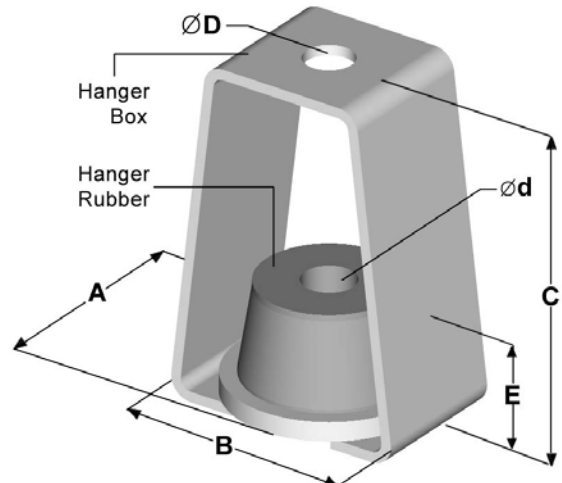
**SPECIFICATION :** Vibration isolators for suspended equipment, piping and ductwork with maximum static deflection requirements under operation load conditions not exceeding 6 mm shall be hangers consisting of a neoprene or synthetic rubber noise absorbing insert encased in a welded steel box.

The rubber insert shall be moulded from oil resistant compounds with cast in load transfer plate at the top and bottom, shall be color-coded or otherwise identified to indicate load capacity.

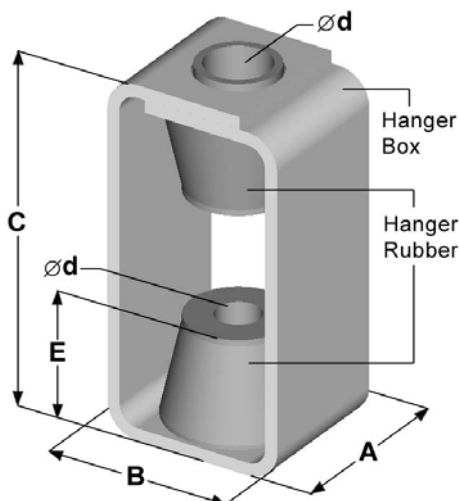
Vibration isolating rubber hanger assembly shall be Model PTH-G, as manufactured by Tozen Sangyo Co., Ltd.



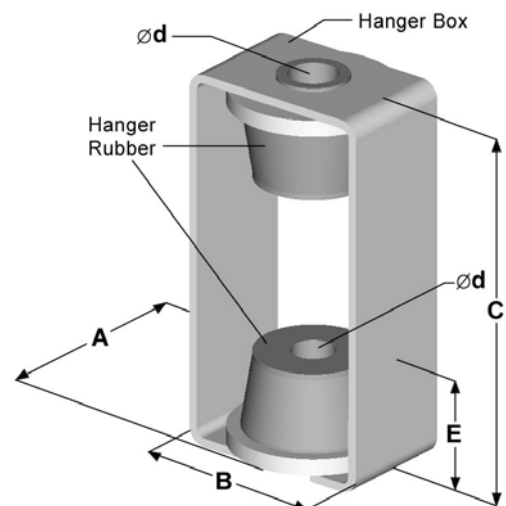
**PTH-G-25, 35, 50**



**PTH-G-80, 120, 150, 200, 300, 450**



**PTH-GG-25, 35, 50**



**PTH-GG-80, 120, 150, 200, 300, 450**

## PTH-G, PTH-GG

### RUBBER HANGER

(mm)

MODEL	DESIGN LOADING		RUBBER COLOR CODE	MAXIMUM STATIC DEFL.	DURA-METER	A	B	C		d		D	E
	(Kgs)	(Lbs)						PTH-G	PTH-GG	PTH-G	PTH-GG	PTH-G	
PTH-G-25	25	55	WHITE	4	40	37	45	90	115	11	11	11	28
PTH-G-35	35	77	YELLOW		50								
PTH-G-50	50	110	ORANGE		55								
PTH-G-80	80	176	PINK	5	40	60	75	105	140	16	16	15	37
PTH-G-120	120	264	RED		50								
PTH-G-150	150	330	ORANGE		55								
PTH-G-200	200	440	PINK	6	40	85	103	132	195	18	18	18	50
PTH-G-300	300	660	RED		50								
PTH-G-450	450	990	GREEN		55								

NOTE-1: Hanger elements have similar straight line deflection curve.

NOTE-2: Please refer to relevant brochure or consult factory for wire or strap suspension systems.



---

**TOZEN (THAILAND) CO., LTD.**

3388/62 18TH FLOOR, SIRINRAT BLDG.,  
RAMA IV Rd., BANGKOK 10110 THAILAND  
TEL : (66) 0-2367-5721 - 8  
FAX : (66) 0-2367-5729, 0-2367-5066  
E-MAIL : [sales@tozen.co.th](mailto:sales@tozen.co.th)  
URL : [www.tozen.co.th](http://www.tozen.co.th)

**TOZEN SANGYO CO., LTD.**

8-4, ASAHI YOSHIKAWA  
SAITAMA 342-008 JAPAN  
TEL : 048-993-1030  
FAX : 048-993-1038